

# MINIATURE PRESSURE REGULATOR

	DESCRIPTION		PRESSURE RANGE bar	CONNECTION thread	SERIES	PAGE
<b>FACTORY-SET OUTLET PRESSURE</b>	higher accuracy		2 / 3 / 4 / 6	G $\frac{1}{4}$ fm	233F	<b>1.02</b>
	without exhaust	17 x 25	2 / 3 / ... / 10	G $\frac{1}{4}$ fm	R13	<b>1.03</b>
	for compressed air	34 x 52	1 / 2 / ... / 8	G $\frac{1}{4}$	231	<b>1.04</b>
	for liquids	34 x 52	1 / 2 / ... / 8	G $\frac{1}{4}$	239A	<b>1.05</b>
	for drinking water	34 x 52	1 / 2 / ... / 8	G $\frac{1}{4}$	239K	9.03
	for oxygen	34 x 52	1 / 2 / ... / 8	G $\frac{1}{4}$	239M	<b>1.05</b>
	relieving		2 / 3 / ... / 8	G $\frac{1}{4}$ - G $\frac{3}{4}$	232	<b>1.06</b>
<b>SLIM DESIGN</b>	extremely small	19 x 40	0.2 ... 2 / 8	M5	RR-M5	<b>1.07</b>
	also with FKM and EPDM	18 x 65	0.2 ... 1.4 / 7	M5 / $\frac{1}{8}$ "NPT	MAR	www*
<b>VERY ACCURATE</b>	very lightweight		0.03 ... 0.24 / 6	$\frac{1}{8}$ "NPT	R800	<b>1.08</b>
	very lightweight		0.03 ... 0.24 / 6	10-32" and flange	R900	<b>1.08</b>
	modular		0.01 ... 0.7 / 7	flange	R6	<b>1.09</b>
	interlockable		0.01 ... 0.7 / 7	M5, G $\frac{1}{8}$ , G $\frac{1}{4}$ , SS	R7	<b>1.10</b>
	FDA approved		0.1 ... 1 / 12	G $\frac{1}{8}$ and G $\frac{1}{4}$	R037	<b>1.11</b>
	plastic		0.1 ... 1 / 12	G $\frac{1}{8}$ and G $\frac{1}{4}$	R039-F	<b>1.12</b>
	inlet pressure compensated		0.1 ... 3 / 6	G $\frac{1}{8}$	R309	<b>1.13</b>
	up to 25 bar supply pressure		0.1 ... 3 / 16	G $\frac{1}{8}$ and G $\frac{1}{4}$	R310	<b>1.13</b>
	slim design		0 ... 0.35 / 7	M5 and flange	RT	www*
	inlet pressure compensated		0.2 ... 2 / 9	flange	R342	www*
	without constant bleed		0.2 ... 2 / 9	G $\frac{1}{8}$ and G $\frac{1}{4}$	R344	www*
	very accurate		0.05 ... 2 / 8	G $\frac{1}{8}$	RI	www*
	very accurate		0.05 ... 2 / 8	G $\frac{1}{8}$ and flange	R90	5.02
<b>STANDARD</b>	increased accuracy		0.1 ... 1 / 12	G $\frac{1}{8}$ and G $\frac{1}{4}$	R039	<b>1.12</b>
	also for water,	brass	0.1 ... 1 / 11	G $\frac{1}{8}$ and G $\frac{1}{4}$	R364	<b>1.14</b>
	made of aluminium		0.1 ... 1 / 11	G $\frac{1}{8}$ and G $\frac{1}{4}$	R374	<b>1.14</b>
	even for oxygen		0.2 ... 2.5 / 8	G $\frac{1}{8}$	R307	<b>1.15</b>
	even for oxygen		0 ... 0.25 / 8	flange	R308	<b>1.16</b>
<b>CARTRIDGE</b>	up to 260 l/min		1 ... 8	G $\frac{1}{8}$ u. G $\frac{1}{4}$	RC	<b>1.17</b>



1

\* visit our webshop: [www.aircom.net](http://www.aircom.net)

# IN-LINE REGULATOR WITH FACTORY-SET OUTLET PRESSURE

R13



**Description**  
In-line pressure regulator with factory-set non-adjustable outlet pressure, reducing from e.g. 10 bar to 5 bar. The regulator R13 is suited for basic pressure control only with an outlet pressure tolerance of  $\pm 30\%$ . The outlet pressure stated below is valid for 15 bar inlet pressure. For other inlet pressure please refer to the according item from the diagram.

**Benefits**

- Higher safety through lower pressure. Tools and equipment protected against pressure damages.
- Cost reduction through substantially reduced air consumption. Longer service life.
- Noise reduction for tools.

**Media**  
compressed air or non-corrosive gases

**Supply pressure**  
max. 15 bar

**Adjustment**  
Select the pressure regulator according to the desired outlet pressure.  
The outlet pressure cannot be subsequently adjusted. This safeguards against tampering.

**Relieving function**  
non-relieving, therefore not recommended for applications such as nailers

**Temperature range**  
0 °C to 60 °C / 32 °F to 140 °F, for appropriately conditioned compressed air down to -30 °C / -22 °F

**Material**  
Body: brass  
Elastomer: NBR/Buna-N, optionally FKM

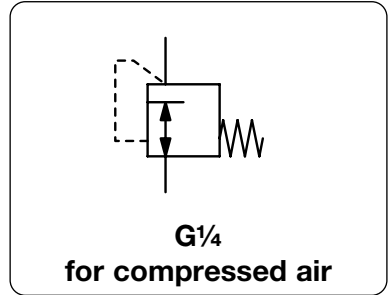

Dimensions			Flow rate	Supply pressure	Connection thread	Outlet pressure	Order number
ØA	B	A/F	l/min*1	max. bar	G	bar	
mm	mm	mm					

Basic accuracy regulator						P: max. 15 bar, non-relieving, outlet pressure accuracy $\pm 30\%$ , made of brass	R13
17	34	17	300	15	G¼ fm	2	R13-02D
						3	R13-02E
						4	R13-02F
						5	R13-02G
						6	R13-02H
						7	R13-02I
						8	R13-02K
						10	R13-02M



R13

## Special options, add the appropriate letter

FKM elastomer R13-02 . V



R13

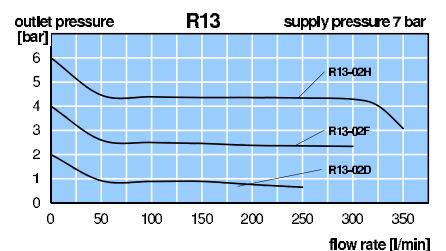
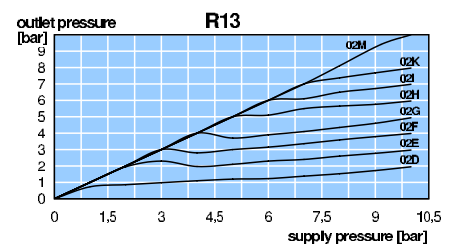
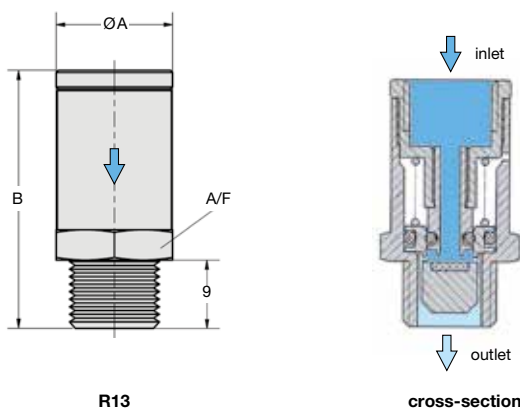

\*1 at 7 bar supply pressure, 6 bar outlet pressure and 2 bar pressure drop

\* Product group



<b>Description</b>	In-line pressure regulator with factory-set non-adjustable outlet pressure, reducing from e.g. 15 bar to 5 bar. The regulator is suited for basic pressure control only with an outlet pressure tolerance of approx. $\pm 10\%$ . Non-relieving function, therefore not recommended for applications such as nailers.
<b>Benefits</b>	<ul style="list-style-type: none"> <li>• Higher safety through lower pressure. Tools and equipment protected against pressure damages</li> <li>• Cost reduction through substantially reduced air consumption</li> <li>• Noise reducing for tools</li> </ul>
<b>Media</b>	compressed air, non-corrosive gases
<b>Supply pressure</b>	max. 18 bar
<b>Adjustment</b>	Select the pressure regulator according to the desired outlet pressure. The outlet pressure cannot be subsequently adjusted. This safeguards against tampering.
<b>Relieving function</b>	non-relieving
<b>Temperature range</b>	0 °C to 60 °C / 32 °F to 140 °F
<b>Material</b>	Body: zinc Elastomer: NBR/Buna-N

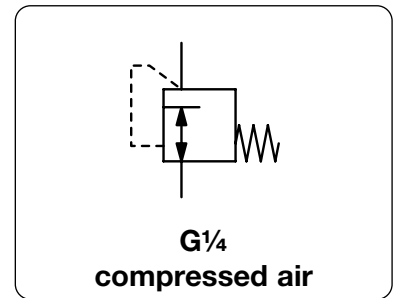

Dimensions			Flow rate	Supply pressure	Connection thread	Outlet pressure	Order number
ØA	B	A/F	l/min*1	max. bar	G	bar*2	
mm	mm	mm					

Regulator for air „SaveAir®“				P: max. 18 bar, non-relieving, accuracy *2, made of zinc		231	
34	52	17	400	18	G1/4	1	<b>231A0210</b>
			600			2	<b>231A0220</b>
			700			3	<b>231A0230</b>
			700			4	<b>231A0240</b>
			700			5	<b>231A0250</b>
			800			6	<b>231A0260</b>
			800			7	<b>231A0270</b>
			800			8	<b>231A0280</b>

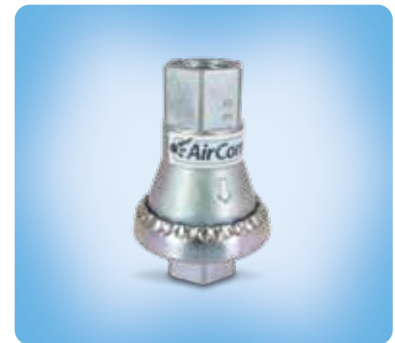

231

### Special options, add the appropriate letter

<b>NPT</b>	connection thread	231A 1 2 . .
<b>deviant pressure range</b>	indicate on order	231A . 2XX

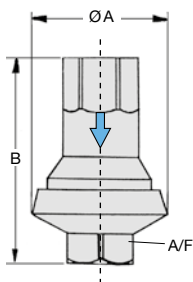

231

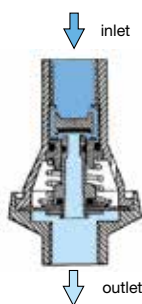

cross-section

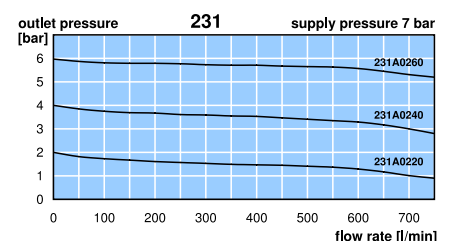

\*1  $P_0 = 12 \text{ bar}$ ;  $\Delta p = 0.5 \text{ bar}$

\*2 Tolerance:  $< 4 \text{ bar} \pm 0.3 \text{ bar}$  (air,  $P_0 = 6 \text{ bar}$ , 10 NI/min)  
 $\geq 4 \text{ bar} \pm 10\%$  (air,  $P_0 = 10 \text{ bar}$ , 10 NI/min)

\* Product group



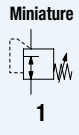

**General information** In-line pressure regulator with factory-set outlet pressure, reducing from e.g. 10 bar to 5 bar. The regulator is suited for basic pressure control only with an outlet pressure tolerance of approx.  $\pm 10\%^2$ . The outlet pressure cannot be subsequently adjusted. This safeguards against tampering.

**Description** 239A: regulator for liquids, compressed air and non-corrosive gases  
239M: medical industry and pharmaceuticals

**Application** water, hydraulic and sprinkler systems, cooler, cleaning systems

**Supply pressure** max. 10 bar for liquids or oxygen  
max. 18 bar for compressed air and non-corrosive gases

**Temperature range** 0 °C to 60 °C / 32 °F to 140 °F

**Material** Body: nickel-plated brass  
Inner parts: brass  
Elastomer: NBR/Buna-N for 239A, FKM for 239M

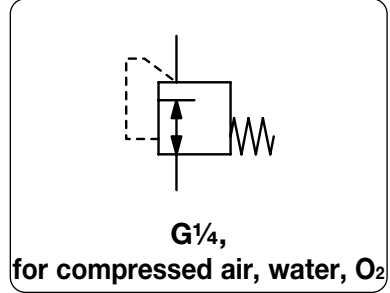

Dimensions			Flow rate		Supply pressure	Connection thread	Outlet pressure	Order number
Ø A	B	A/F	water	air	max. bar	G	bar*2	
mm	mm	mm	l/min*1					

Regulator for compr. air / water						made of brass, P <sub>i</sub> : max. 18 bar / 10 bar, NBR/Buna-N, outlet pressure accuracy *2	239A	
34	52	17	10	400	18/10	G <sup>1</sup> / <sub>4</sub>	1	239A0210
			10	600			2	239A0220
			10	700			3	239A0230
			10	700			4	239A0240
			10	700			5	239A0250
			10	800			6	239A0260
			10	800			7	239A0270
			10	800			8	239A0280



239A / 239M

Regulator for oxygen						made of brass, P <sub>i</sub> : max. 10 bar, FKM, outlet pressure accuracy *2	239M	
34	52	17	-	400	10	G <sup>1</sup> / <sub>4</sub>	1	239M0210
			-	600			2	239M0220
			-	700			3	239M0230
			-	700			4	239M0240
			-	700			5	239M0250
			-	800			6	239M0260
			-	800			7	239M0270
			-	800			8	239M0280

**Special options,** add the appropriate letter

**NPT** connection thread 239A1 . . .

**deviant pressure range** indicate on order 239 . . . 2XX

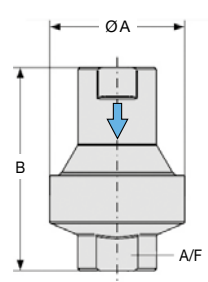

239A / 239M

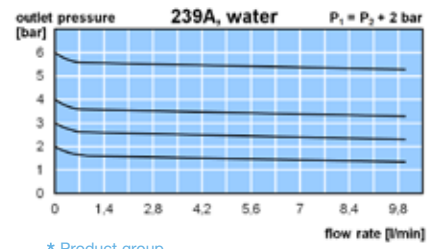
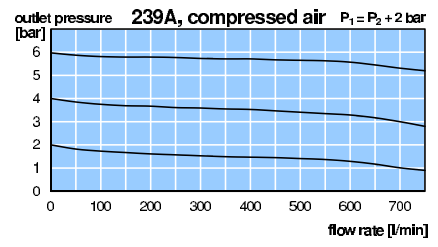
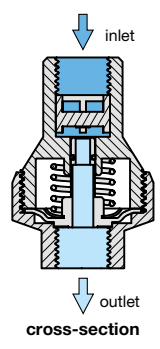

\*1 P<sub>i</sub> = 10 bar; Δp = 0.8 bar

\*2 Tolerance: < 4 bar ± 0.3 bar (air, P<sub>e</sub> = 6 bar, 10 NI/min)  
≥ 4 bar ± 10% (air, P<sub>e</sub> = 10 bar, 10 NI/min)

\* Product group

PDF CAD  
www.aircom.net

Order example:  
239A0210

<b>Description</b>	In-line pressure regulator with factory-set outlet pressure, reducing from e.g. 15 bar to 6 bar. With an outlet pressure tolerance of only ±10% <sup>2</sup> it is especially suitable for nailing machines.
<b>Benefits</b>	<ul style="list-style-type: none"> <li>• Higher safety through lower pressure. Tools and equipment protected against pressure damages.</li> <li>• Cost reduction through substantially reduced air consumption. Longer service life.</li> <li>• Noise reduction for tools.</li> </ul>
<b>Media</b>	compressed air or non-corrosive gases
<b>Supply pressure</b>	max. 25 bar
<b>Adjustment</b>	Select the pressure regulator according to the desired outlet pressure. The outlet pressure cannot be subsequently adjusted. This safeguards against tampering.
<b>Relieving function</b>	relieving at removal of supply pressure
<b>Temperature range</b>	0 °C to 80 °C / 32 °F to 176 °F
<b>Material</b>	Body: aluminium Elastomer: NBR/Buna-N

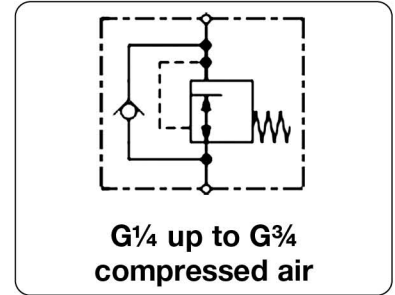

Dimensions				Flow rate	Supply pressure	Connection thread	Outlet pressure	Order number
ØA	B	A/F 1	A/F 2					
mm	mm	mm	mm	l/min*1	max. bar	G	bar*2	

Regulator with relieving function				P1: max. 25 bar, accuracy*2, aluminium		232		
19	69	17	19	500	25	G1/4a	2	232F0220
							3	232F0230
							4	232F0240
							5	232F0250
							6	232F0260
							7	232F0270
							8	232F0280
							19	59
3	232A0230							
4	232A0240							
5	232A0250							
6	232A0260							
7	232A0270							
8	232A0280							
25	63	22	25	1400	25	G3/8		
							3	232A0330
							4	232A0340
							5	232A0350
							6	232A0360
							7	232A0370
							8	232A0380
							30	68
3	232A0430							
4	232A0440							
5	232A0450							
6	232A0460							
7	232A0470							
8	232A0480							
40	102	34	40	2500	25	G3/4		
							4	232A0540
							6	232A0560
							8	232A0580



232F with female / male thread



232A with female thread

## Special options, add the appropriate letter

- NPT connection thread 232. 1 . . .
- deviant pressure range indicate on order 232. . . X X

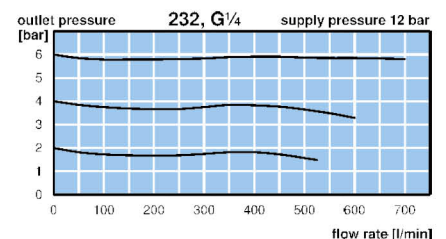
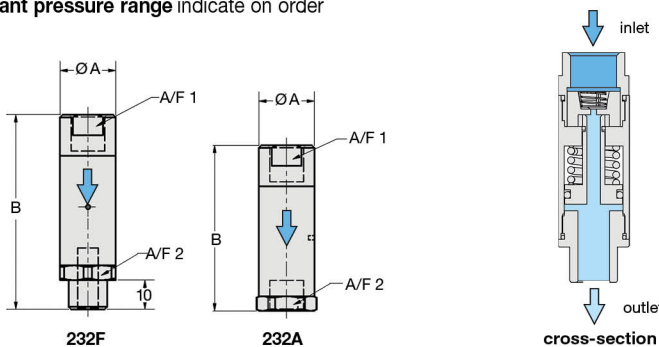

\*1 P<sub>s</sub> = 12 bar; Δp = 0.5 bar  
\*2 Tolerance: < 4 bar ± 0.3 bar (air, P<sub>s</sub> = 6 bar, 10 Nl/min)  
≥ 4 bar ± 10% (air, P<sub>s</sub> = 10 bar, 10 Nl/min)

\* Product group

PDF CAD  
www.aircom.net



Order example:  
232F0220

# MICRO PRESSURE REGULATOR

RR-M5



<b>Description</b>	Highly compact piston-operated regulator, suitable for panel mounting and basic pressure regulation.
<b>Media</b>	compressed air, non-corrosive gases or liquids
<b>Supply pressure</b>	max. 6 bar at 0.2 ... 2 bar pressure range, max. 10 bar at 1 ... 8 bar pressure range
<b>Adjustment</b>	by knurled-head screw with locknut
<b>Relieving function</b>	relieving for air, non-relieving for water
<b>Gauge port</b>	not available
<b>Mounting position</b>	any
<b>Temperature range</b>	0 °C to 60 °C / 32 °F to 140 °F, for appropriately conditioned compressed air down to -30 °C / -22 °F
<b>Material</b>	Body: nickel-plated brass Elastomer: NBR/Buna-N Inner valve: stainless steel and brass

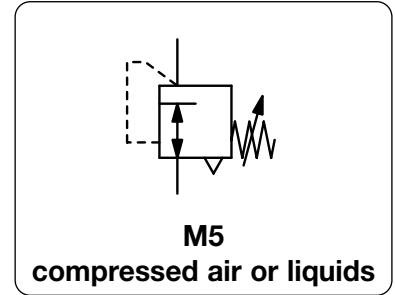

Dimensions			Flow rate	Supply pressure	Connection	Pressure range	Order number
A	B	A/F	l/min*1	max. bar	thread	bar	
mm	mm	mm			M5		

Pressure regulator for air				supply pressure max. 6 / 10 bar, relieving	RR-M5
19	40	17	70	6	RR-M5A
17	40	17	70	10	RR-M5C



RR-M5

Pressure regulator for water				supply pressure max. 6 / 10 bar, non-relieving	RR-M5
19	40	17	1.2	6	RR-M5AK
17	40	17	1.2	10	RR-M5CK



RR-M5

**Special options,** add the appropriate letter  
for oxygen specially cleaned, with oxygen grease minimum purchase 50 pieces RR-M5 . . K15

**Accessories,** enclosed  
plastic panel nut M12x1K

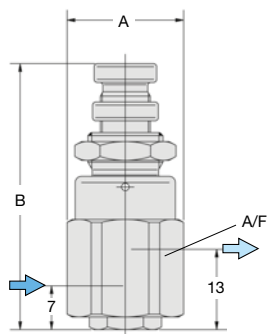
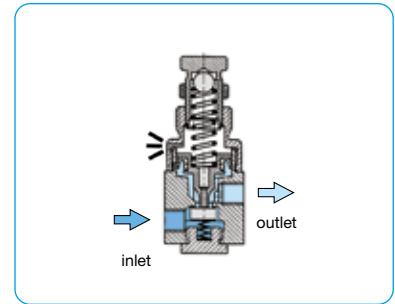

RR-M5

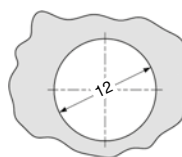

panel cut-out

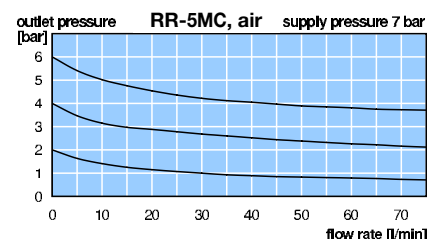

\*1 for compressed air: 7 bar supply pressure and 6 bar outlet pressure and 2 bar pressure drop  
for water: supply pressure 2 bar above outlet pressure

\* Product group

PDF CAD  
www.aircom.net



Order example:  
RR-M5A

# PLASTIC MINIATURE PRECISION PRESSURE REGULATOR

# R800 / R900

<b>Description</b>	Miniature precision regulator with high supply sensitivity, small dimension, low weight. Hysteresis-free adjustment up to 20 turns. compressed air or non-corrosive gases	
<b>Media</b>	max. 10 bar	
<b>Supply pressure</b>		
<b>Accuracy</b>	<b>R800 / R900 / R901</b>	<b>R810 / R910 / R911</b>
	< 7 mbar pressure deviation	< 20 mbar pressure deviation
	< 7 mbar pressure deviation	< 17 mbar pressure deviation
	< 2.5 mbar	< 5 mbar
<b>Air consumption</b>	0.35 l/min at 7 bar supply	pressure increase for flow <20 ml/min
<b>Relieving function</b>	relieving, optionally non-relieving	
<b>Relief capacity</b>	15 l/min at 0.35 bar outlet above set-point	
<b>Temperature range</b>	4 °C to 66 °C / 40 °F to 150 °F	
<b>Material</b>	Body: polysulfones	Elastomer: NBR/Buna-N
	Inner valve: stainless steel and acetal	

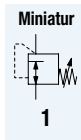
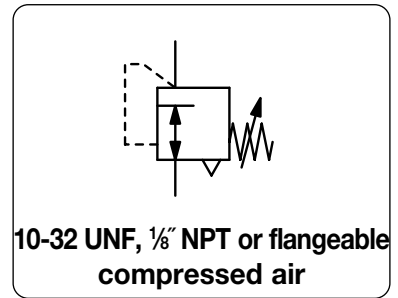

Dimensions			Pressure adjustment	Flow rate	Pressure range	Order number for manifold	Order number 10-32 UNF standard
A	B	C	by	l/min*1	bar	with o-ring	
mm	mm	mm					

Precision pressure regulator						supply pressure max. 10 bar, relieving, with constant bleed	R900
29	78	8	knob	65	0.03 ... 0.24	<b>R900-3,5MWK</b>	<b>R900-3,5WK</b>
					0.03 ... 0.7	<b>R900- 10MWK</b>	<b>R900- 10WK</b>
					0.03 ... 2.1	<b>R900- 30MWK</b>	<b>R900- 30WK</b>
					0.03 ... 4.2	<b>R900- 60MWK</b>	<b>R900- 60WK</b>
					0.03 ... 6.2	<b>R900- 90MWK</b>	<b>R900- 90WK</b>
29	60	8	spindle	65	0.03 ... 0.24	<b>R900-3,5WOS</b>	<b>R900-3,5WOS</b>
					0.03 ... 0.7	<b>R900- 10WOS</b>	<b>R900- 10WOS</b>
					0.03 ... 2.1	<b>R900- 30WOS</b>	<b>R900- 30WOS</b>
					0.03 ... 4.2	<b>R900- 60WOS</b>	<b>R900- 60WOS</b>
					0.03 ... 6.2	<b>R900- 90WOS</b>	<b>R900- 90WOS</b>
29	43	8	preset	65	to be indicated	<b>R901- .. M</b>	<b>R901- ..</b>



## Special options, add the appropriate letter

1/8" NPT	connection thread, width 40 mm	R8...W...
non-relieving	without constant bleed	R.1.....
for oxygen	specially cleaned	R.....15



## Accessories, enclosed

mounting bracket made of steel for R800 and R900 **BW15-01**

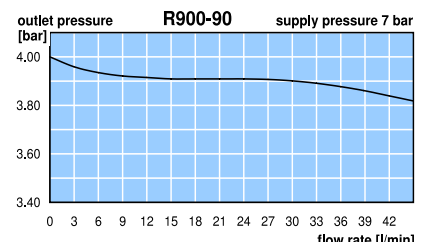
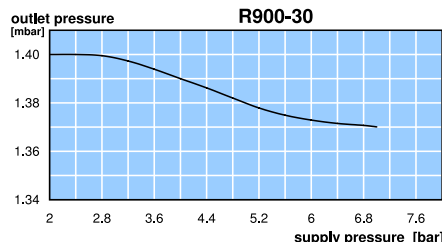
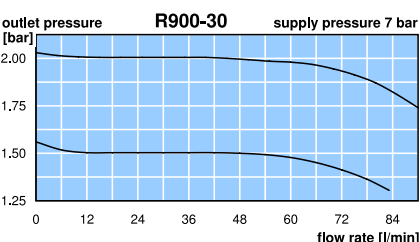
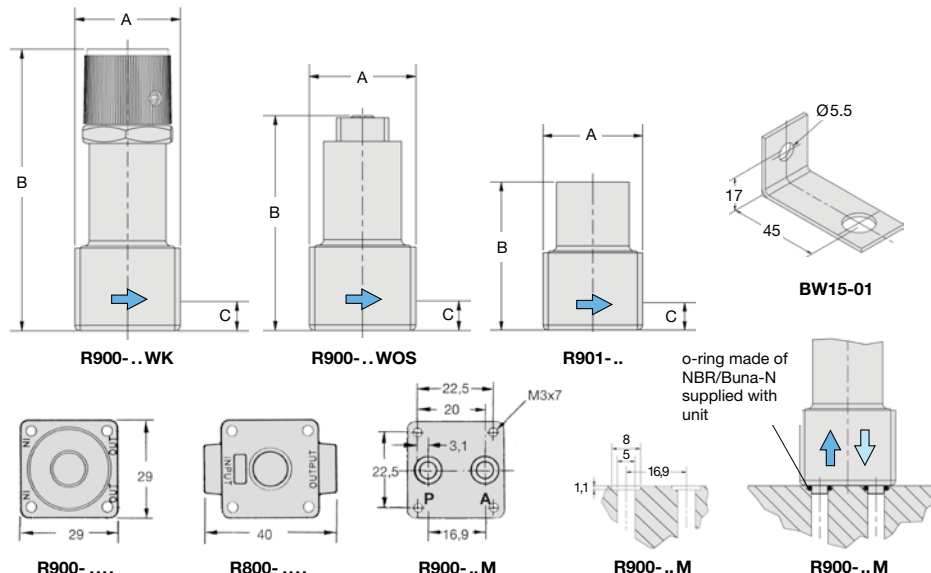

\*1 at 7 bar supply pressure and max. outlet pressure

\* Product group

PDF CAD  
www.aircom.net



Order example:  
**R900-3,5MWK**

# MODULAR MINIATURE PRESSURE REGULATOR „AIRLOGIC“

## R6 / RP / M5000

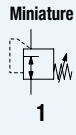

### Description

**Pressure regulator R6** Design as R7 but for bottom-sided flange assembly via fittings and o-rings made of NBR/Buna-N. Mounting through four screws (M3) with extremely small screw heads.

**Pressure regulator RP** This model guards against unauthorised tampering of pressure. Alternatively available with preset pressure. The pressure is to be set between 30 mbar and 2.8 bar. Its height is reduced to 49 mm.

**Diverter block M5000** Features four ports sideways and one on top. All ports can be provided with threads or blank slides, the ports sideways optionally with connector slides.

**Top cover**

**Connector slide**

**Assembly** After loosening the bottom screw any placements of threads, connector and blank slides are possible. Sealing results from o-rings made of NBR/Buna-N.

**Temperature range** 4 °C to 70 °C / 39.2 °F to 158 °F

**Material** Body: glass fiber-reinforced Celcon Inner valve: stainless steel and Celcon  
Elastomer: NBR/Buna-N

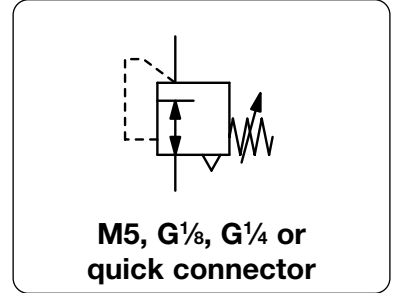

**M5, G $\frac{1}{8}$ , G $\frac{1}{4}$  or quick connector**

Dimensions			Flow rate l/min*1	Supply pressure max. bar	Connection thread G/ flange	Pressure range bar	Order number
A	B	C					

Precision regulator with flange			Flow rate l/min*1	Supply pressure max. bar	Connection thread G/ flange	Pressure range bar	Order number
A	B	C					
47	92	-	140	10	flange	0.01 ... 0.7 0.02 ... 2.1 0.03 ... 4.1 0.03 ... 7.0	<b>R6</b> R6-010-B1BB R6-030-B1BB R6-060-B1BB R6-100-B1BB



R6

Regulator with adjustment lock			Flow rate l/min*1	Supply pressure max. bar	Connection thread G/ flange	Pressure range bar	Order number
A	B	C					
47	49	14	140	10	G $\frac{1}{8}$	0.03 ... 2.8 *2	<b>RP</b> RP7- 040-111B
32	49	-	-	-	flange	0.03 ... 2.8 *2	RP6- 040-B1BB



RP7 for socket wrench

RP6 with flange

Diverter block G $\frac{1}{8}$			Flow rate l/min*1	Supply pressure max. bar	Connection thread G/ flange	Pressure range bar	Order number
A	B	C					
47	42	14	without filter with filter, 380 $\mu$ m	-	G $\frac{1}{8}$ connection	-	<b>M5000</b> M5000-11111 M5001-11111

### Special options and accessories

see adjoining page

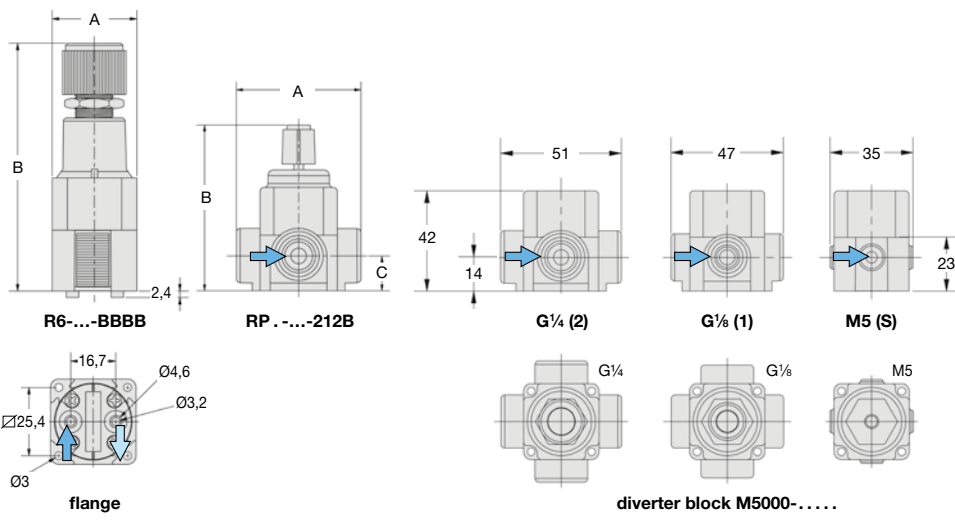

M5000-SBSBS

M5000-1S1SB



M5000-11111, G $\frac{1}{8}$

M5000-22222, G $\frac{1}{4}$

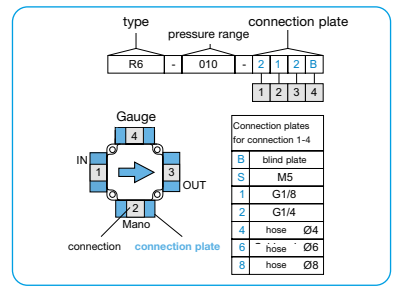
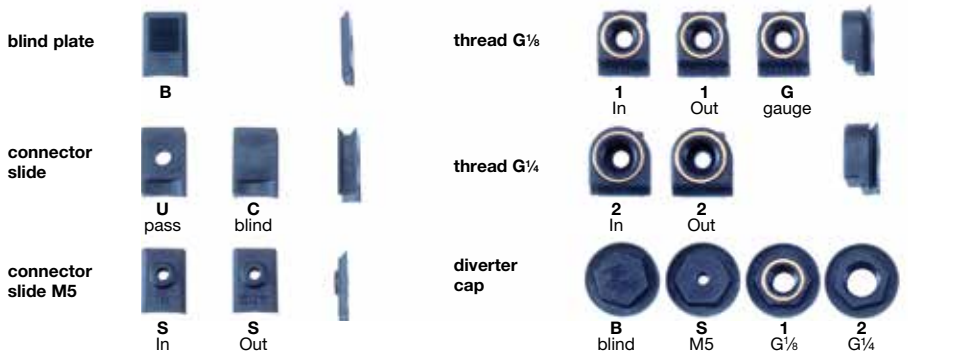

connector slides configuration

\*1 at 7 bar supply pressure, 6 bar outlet pressure and 1 bar pressure drop

\*2 indicate preset pressure on order

\* Product group

PDF CAD  
www.aircom.net

**Order example:**  
R6-010-B1BB



<b>Description</b>	Miniature pressure regulator with unique modular dovetail design allowing its individual use or assembly into a modular combination of pneumatic components through connector slides.	
<b>Identification marking</b>	The item no. includes a four-digit number starting with the input port and continuing counterclockwise. The digit corresponds with the type of connector slide, e.g. 1 for G $\frac{1}{8}$ , 2 for G $\frac{1}{4}$ or B for blank.	
<b>Pressure regulator R7</b>	Designed for precise regulation of pressure. The regulator possesses a 20 turn adjustment range and excellent repeatability. The valve seat is protected by a filter/strainer at the input port.	
<b>Media</b>	5 $\mu$ m filtered compressed air and non-corrosive gases	<b>Supply pressure</b> max. 10 bar
<b>Accuracy</b>	at supply pressure variation of 1 bar: at supply pressure removal/reapplication: at variations in temperature of 25 °C / K:	< 10 mbar pressure deviation < 10 mbar pressure deviation < 10 mbar pressure deviation
<b>Air consumption</b>	0.3 l/min at 7 bar supply pressure	<b>Adjustment</b> by knob
<b>Relieving function</b>	relieving	<b>Mounting position</b> any
<b>Gauge port</b>	G $\frac{1}{8}$ via threaded slide	

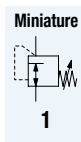
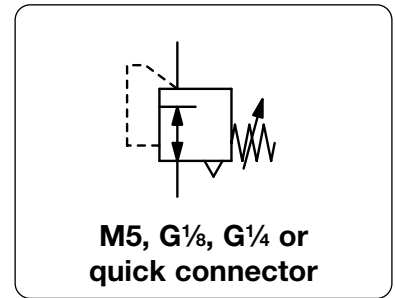

Dimensions			Flow rate l/min*1	Supply pressure max. bar	Connection thread G	Pressure rang bar	Order number
A	B	C					

Precision regulator				with adjusting knob, relieving, gauge port G $\frac{1}{8}$ on one side	R7		
47	92	14	140			10	G $\frac{1}{8}$
51	92	14	140	10	G $\frac{1}{4}$	0.01...0.7 0.02...2.1 0.03...4.1 0.03...7.0	R7-010-212B R7-030-212B R7-060-212B R7-100-212B



R7-...-1B1B, G $\frac{1}{8}$



R7-...-2B2BS, G $\frac{1}{4}$

### Special options, add the appropriate letter or number

<b>with spindle</b>	screwdriver adjustment, height 77 mm	R.-...-...S
<b>thread</b>	M5 connection thread	R.-...-S...
	G $\frac{1}{8}$	R.-...-1...
	G $\frac{1}{4}$	R.-...-2...
<b>quick connector</b>	external diameter of hose	R.-...-4...
	$\varnothing$ 4	R.-...-6...
	$\varnothing$ 6	R.-...-8...
	$\varnothing$ 8	R.-...-B...
<b>breach plate</b>		R.-...-U...
<b>connection plate</b>	with permanent pressure supply	R.-...-C...
	without passage, modular combination of two devices	R.-...-W...
<b>wall mounting</b>	at breach plate	



R7-...-SBSBS with spindle, M5



R7-...-4B4B w/ quick connector  $\varnothing$  4

### Accessories, enclosed

<b>pressure gauge</b>	$\varnothing$ 23 mm, 0...*2 bar, G $\frac{1}{8}$	MA2301-...*2
-----------------------	--	--------------

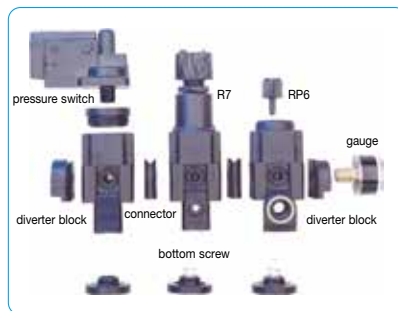
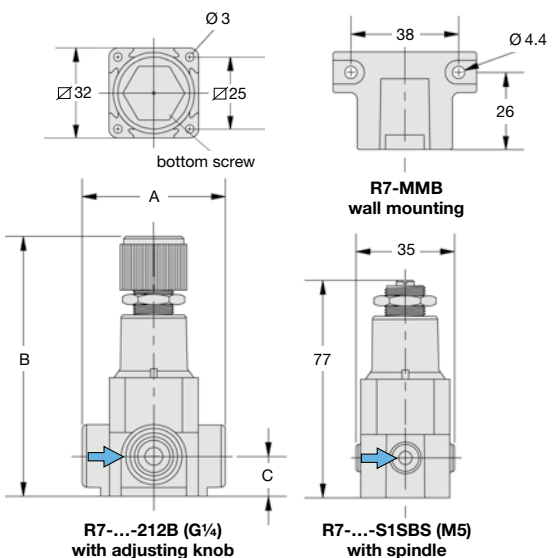

example for assembly

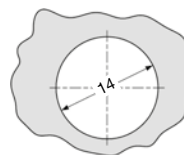

panel cut-out



example for assembly

\*1 at 7 bar supply pressure, 6 bar outlet pressure and 1 bar pressure drop  
\*2 04 = 0...4 bar, 06 = 0...6 bar, 10 = 0...10 bar

\* Product group



# MINIATURE PRESSURE REGULATOR WITH FDA APPROVAL

R037

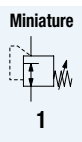

<b>Description</b>	Diaphragm miniature pressure regulator made of plastic and of small and lightweight design. All parts coming into contact with the medium are approved by the FDA.
<b>Application area</b>	food industry and water circulation, e.g. for dialysis devices
<b>Media</b>	compressed air, non-corrosive gases, deionized water or other liquids
<b>Supply pressure</b>	max. 16 bar
<b>Adjustment</b>	by plastic knob with snap-lock
<b>Relieving function</b>	non-relieving
<b>Gauge port</b>	not available
<b>Mounting position</b>	any
<b>Temperature range</b>	0 °C to 50 °C / 32 °F to 122 °F
<b>Material</b>	Body: POM technopolymer with thread insert of SST 316, approved by FDA and WRAS Elastomer: EPDM with thread insert of SST 316, approved by FDA and KTW Valve and O-ring: Hytrel and EPDM, FDA-approved Grease: Klüber, UH184-201

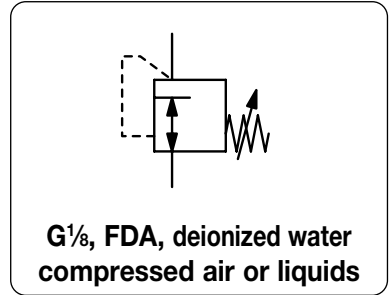

Dimensions			Flow rate		Connection	Pressure	Order
A	B	C	water	air	thread	range	number
mm	mm	mm	l/min*1	l/min	G	bar	

Pressure regulator w. FDA approval							supply pressure max. 16 bar, non-relieving EPDM, with inlet pressure compensation	R037
41	86	11	5	350	G <sup>1</sup> / <sub>8</sub>	0,1 ... 1	R037-010K	
						0,1 ... 2	R037-01AK	
						0,2 ... 4	R037-01BK	
						0,3 ... 8	R037-01CK	
						0,4 ... 12	R037-01DK	
41	86	11	5	380	G <sup>1</sup> / <sub>4</sub>	0,1 ... 1	R037-020K	
						0,1 ... 2	R037-02AK	
						0,2 ... 4	R037-02BK	
						0,3 ... 8	R037-02CK	
						0,4 ... 12	R037-02DK	



R037

**Special options,** add the appropriate letter or number  
for oxygen                      specially cleaned, with oxygen grease                      R037-0...K15

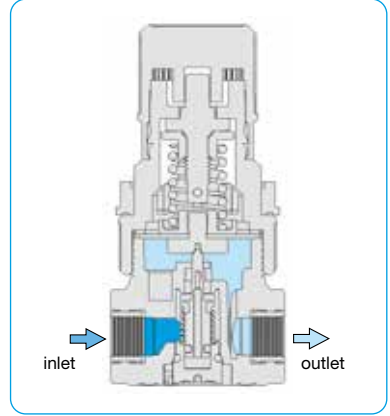

cross-section

Accessories, enclosed		
mounting bracket	made of steel	BW30-02
mounting nut	made of plastic	M30x1,5K
	made of aluminium	M30x1,5A

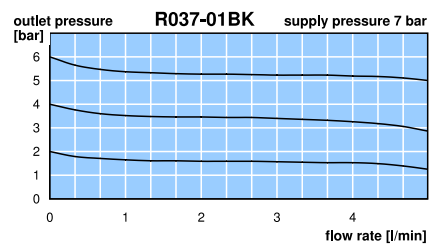
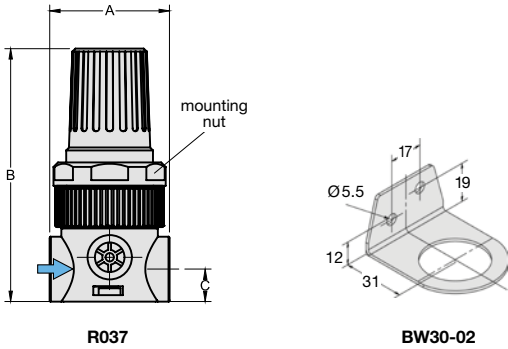

\*1 supply pressure 1 bar above outlet pressure

\* Product group

# PRECISION PRESSURE REGULATOR MADE OF PLASTIC

# R039

<b>Description</b>	Diaphragm miniature pressure regulator of small and lightweight design. The regulator has increased accuracy due to a rolling diaphragm and a piston compensated to inlet pressure.	
<b>Media</b>	compressed air, non-corrosive gases or liquids	
<b>Supply pressure</b>	max. 16 bar	
<b>Air consumption</b>	R039 without constant bleed	R039-F with max. 3 l/min air consumption
<b>Adjustment</b>	by plastic knob with snap-lock	
<b>Relieving function</b>	relieving for compressed air,	red adjusting knob
	non-relieving for liquids,	black adjusting knob
<b>Gauge port</b>	G $\frac{1}{8}$ on both sides of the body, screw plugs supplied	
<b>Mounting position</b>	any	
<b>Temperature range</b>	0 °C to 50 °C / 32 °F to 122 °F for NBR/Buna-N	
<b>Material</b>	Body: POM with brass thread insert Elastomer: NBR/Buna-N Inner valve: brass	

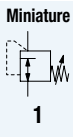
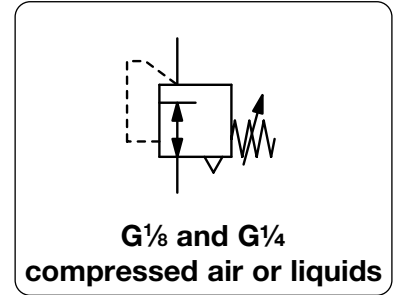

Dimensions			Flow rate		Connection	Pressure	Order number	Order number
A	B	C	water	air	thread	range	for water	for compressed air
mm	mm	mm	l/min*1	l/min*1	G	bar	non-relieving	relieving

Regulator w. increased accuracy							supply pressure max. 16 bar, w. rolling diaphragm, inlet pressure-compensated		R039
41	86	11	5	350	G $\frac{1}{8}$	0.1 ... 1	<b>R039-010K</b>	<b>R039-010</b>	<b>R039-010</b>
						0.2 ... 2	<b>R039-01AK</b>	<b>R039-01A</b>	<b>R039-01A</b>
						0.2 ... 4	<b>R039-01BK</b>	<b>R039-01B</b>	<b>R039-01B</b>
						0.3 ... 8	<b>R039-01CK</b>	<b>R039-01C</b>	<b>R039-01C</b>
						0.3 ... 12	<b>R039-01DK</b>	<b>R039-01D</b>	<b>R039-01D</b>
41	86	11	5	380	G $\frac{1}{4}$	0.1 ... 1	<b>R039-020K</b>	<b>R039-020</b>	<b>R039-020</b>
						0.2 ... 2	<b>R039-02AK</b>	<b>R039-02A</b>	<b>R039-02A</b>
						0.2 ... 4	<b>R039-02BK</b>	<b>R039-02B</b>	<b>R039-02B</b>
						0.3 ... 8	<b>R039-02CK</b>	<b>R039-02C</b>	<b>R039-02C</b>
						0.3 ... 12	<b>R039-02DK</b>	<b>R039-02D</b>	<b>R039-02D</b>



Precision pressure regulator							with air consumption, P <sub>i</sub> : max. 16 bar, w. rolling diaphragm, inlet pressure-compensated		R039-F
41	86	11	5	350	G $\frac{1}{8}$	0.1 ... 1		<b>R039-010F</b>	<b>R039-010F</b>
						0.2 ... 2		<b>R039-01AF</b>	<b>R039-01AF</b>
						0.2 ... 4		<b>R039-01BF</b>	<b>R039-01BF</b>
						0.3 ... 8		<b>R039-01CF</b>	<b>R039-01CF</b>
						0.3 ... 12		<b>R039-01DF</b>	<b>R039-01DF</b>
41	86	11	5	380	G $\frac{1}{4}$	0.1 ... 1		<b>R039-020F</b>	<b>R039-020F</b>
						0.2 ... 2		<b>R039-02AF</b>	<b>R039-02AF</b>
						0.2 ... 4		<b>R039-02BF</b>	<b>R039-02BF</b>
						0.3 ... 8		<b>R039-02CF</b>	<b>R039-02CF</b>
						0.3 ... 12		<b>R039-02DF</b>	<b>R039-02DF</b>



Special options, add the appropriate letter		
<b>adjustment lock</b>	non-adjustable knob	R039-0 . . T
<b>without gauge port</b>		R039-0 . . X02
<b>for oxygen</b>	especially cleaned, with oxygen grease	not for R039-0..F R039-0 . . K15

## Accessories, enclosed B\*

<b>pressure gauge</b>	Ø 40 mm, 0...*2 bar, G $\frac{1}{8}$	<b>MA4001- . . *2</b>
<b>mounting bracket</b>	made of steel	<b>BW30-02</b>
<b>mounting nut</b>	made of plastic	<b>M30x1,5K</b>
	made of aluminium	<b>M30x1,5A</b>

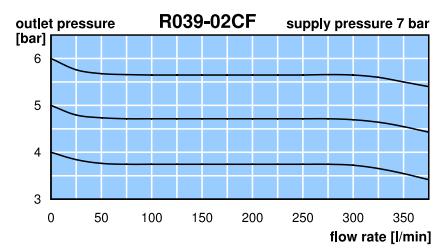
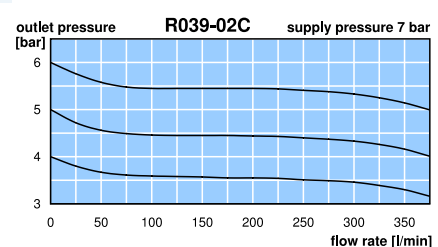
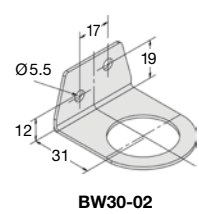
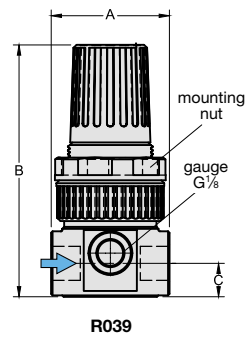

\*1 at 7 bar supply pressure, 6 bar outlet pressure and 1 bar pressure drop, for water: supply pressure 2 bar above outlet pressure  
\*2 02 = 0...2.5 bar, 04 = 0...4 bar, 10 = 0...10 bar, 16 = 0...16 bar



<b>Description</b>	Diaphragm pressure regulator made of brass without constant bleed.		
<b>Media</b>	compressed air, non-corrosive gases or liquids		
<b>Supply pressure</b>	max. 25 bar, max. 14 bar for the oxygen version		
<b>Adjustment</b>	by plastic knob with snap-lock		
<b>Relieving function</b>	relieving, optionally non-relieving		
<b>Gauge port</b>	G $\frac{1}{8}$ on both sides of the body, one screw plug supplied		
<b>Mounting position</b>	any		
<b>Temperature range</b>	0 °C to 60 °C / 32 °F to 140 °F for NBR / Buna-N 0 °C to 80 °C / 32 °F to 176 °F for FKM or EPDM for appropriately conditioned compressed air down to -30 °C / -22 °F		
<b>Material</b>	Body: brass Spring cage: POM	Elastomer: NBR/Buna-N, optionally FKM or EPDM, e.g. for brake fluid Inner valve: stainless steel and brass	

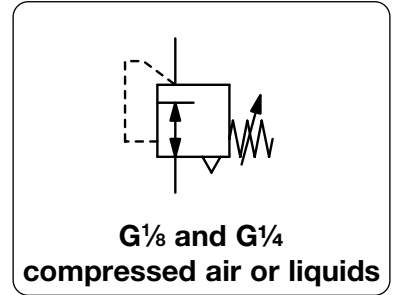

Dimensions			Flow rate l/min*1	Supply pressure max. bar	Connection thread G	Pressure range bar	Order number
A	B	C					

Pressure regulator				supply pressure max. 25 bar, relieving, gauge port G $\frac{1}{8}$ , inlet pressure-compensated		R310	
40	80	16.5	220	25	G $\frac{1}{8}$	0.1... 3	R310-01B
						0.4... 10	R310-01D
						0.5... 16	R310-01E
40	80	16.5	220	25	G $\frac{1}{4}$	0.1... 3	R310-02B
						0.4... 10	R310-02D
						0.5... 16	R310-02E



## Special options, add the appropriate letter or number

<b>non-relieving</b>	without relieving function	R310-0. . K
<b>for oxygen</b>	specially cleaned, P $_1$ : max. 14 bar, P $_2$ : max. 10 bar	R310-0. . K15
<b>FKM elastomer</b>		R310-0. . V
<b>EPDM elastomer</b>	non-relieving, e.g. for brake fluid	R310-0. . KE

## Accessories, enclosed

<b>pressure gauge</b>	Ø 40 mm, 0...*2 bar, G $\frac{1}{8}$	R310 only	<b>MA4001-...*2</b>
<b>mounting bracket</b>	made of steel		<b>BW30-02</b>
<b>mounting nut</b>	made of plastic		<b>M30x1,5K</b>
	made of brass		<b>M30x1,5M</b>

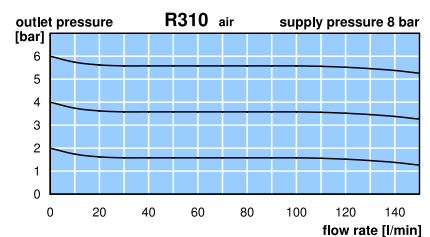
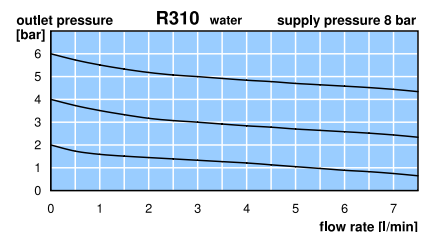
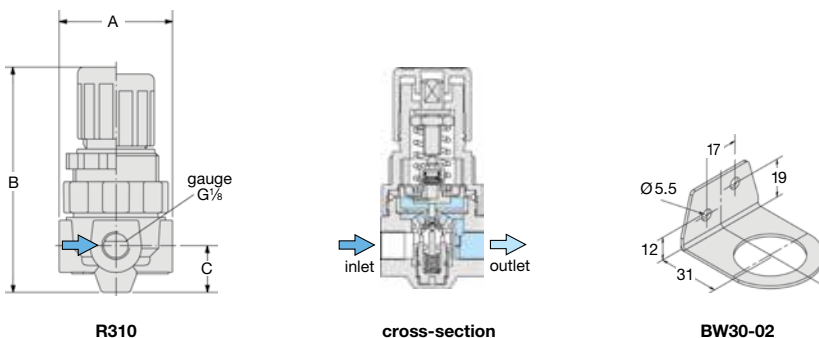

\*1 for compressed air: 8 bar supply pressure, 4 bar outlet pressure and 1 bar pressure drop  
\*2 01 = 0...1 bar, 04 = 0...4 bar, 10 = 0...10 bar, 16 = 0...16 bar

\* Product group

Gauges: see chapter for measuring devices

PDF CAD  
www.aircom.net

Order example:  
R310-01B

# MINIATURE PRESSURE REGULATOR

## R364 / R374

<b>Description</b>	Compact regulator with diaphragm
<b>Media</b>	compressed air, non-corrosive gases or liquids
<b>Supply pressure</b>	max. 21 bar
<b>Adjustment</b>	by plastic knob with snap-lock
<b>Relieving function</b>	relieving, optionally non-relieving
<b>Gauge port</b>	G $\frac{1}{8}$ on both sides of the body, screw plugs supplied
<b>Mounting position</b>	any
<b>Temperature range</b>	0 °C to 50 °C / 32 °F to 122 °F, for appropriately conditioned compressed air down to -30 °C / -22 °F
<b>Material</b>	Body: brass at R364, aluminium at R374 Spring cage: glass fibre reinforced plastic, optionally brass Elastomer: NBR/Buna-N, optionally FKM Inner valve: brass, optionally stainless steel

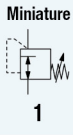
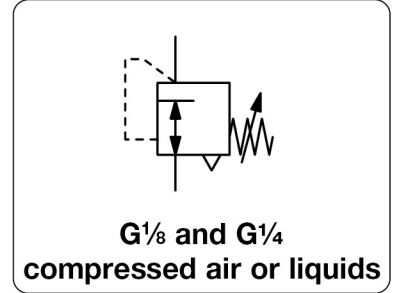

Dimensions			Flow rate		Connection thread	Pressure range	Order number
A	B	C			G	bar	
mm	mm	mm	m <sup>3</sup> /h*1	l/min*1			

Brass pressure regulator					supply pressure max. 21 bar, relieving	R364	
35	76	12	27	450	G $\frac{1}{8}$	0.1...1.0 0.2...1.8 0.2...4.0 0.3...9.0 0.5... 11	R364-010 R364-01A R364-01B R364-01C R364-01D
35	76	12	27	450	G $\frac{1}{4}$	0.1...1.0 0.2...1.8 0.2...4.0 0.3...9.0 0.5... 11	R364-020 R364-02A R364-02B R364-02C R364-02D



R364  
made of brass

Aluminium pressure regulator					supply pressure max. 21 bar, relieving	R374	
35	76	12	27	450	G $\frac{1}{8}$	0.1...1.0 0.2...1.8 0.2...4.0 0.3...9.0 0.5... 11	R374-010 R374-01A R374-01B R374-01C R374-01D
35	76	12	27	450	G $\frac{1}{4}$	0.1...1.0 0.2...1.8 0.2...4.0 0.3...9.0 0.5... 11	R374-020 R374-02A R374-02B R374-02C R374-02D



R374  
made of aluminium

Special options, add the appropriate letter		
<b>NPT</b>	connection thread	R3.4-0...N
<b>non-relieving</b>	without relieving function	R3.4-0...K
<b>adjustment lock</b>	socket wrench adjustment, height 64 mm	R3.4-0...T
<b>free of grease and oil</b>	specially cleaned, suitable for oxygen	R3.4-0...L
<b>FKM elastomer</b>	inner parts made of brass	R3.4-0...X64
	inner parts made of stainless steel	R3.4-0...X08

Accessories, enclosed		
<b>pressure gauge</b>	Ø 40 mm, 0... <sup>*2</sup> bar, G $\frac{1}{8}$	MA4001-... <sup>*2</sup>
<b>mounting bracket</b>	made of steel	BW30-02
<b>mounting nut</b>	made of plastic	M30x1,5K
	made of aluminium	M30x1,5A



R364-02CT with adjustment lock    R364-02CX82 brass throughout

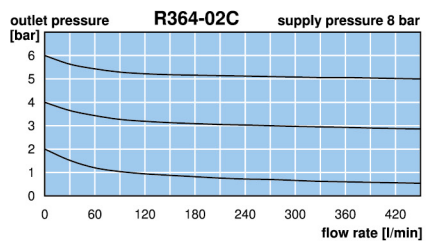
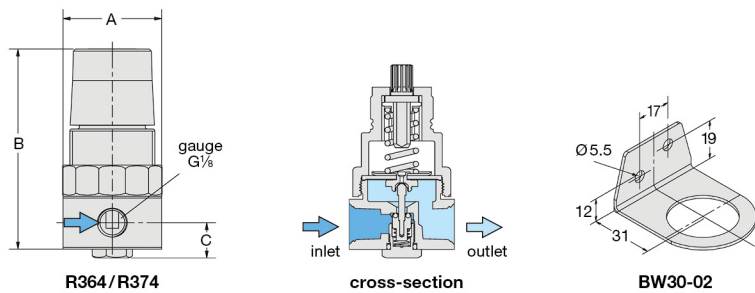

\*1 at 8 bar supply pressure, 6 bar outlet pressure and 1 bar pressure drop  
\*2 01 = 0...1 bar, 02 = 0...2,5 bar, 04 = 0...4 bar, 10 = 0...10 bar, 16 = 0...16 bar

# MINIATURE PRESSURE REGULATOR

R364 / R374

<b>Description</b>	Compact regulator with diaphragm
<b>Media</b>	compressed air, non-corrosive gases or liquids (by R364)
<b>Supply pressure</b>	max. 21 bar
<b>Adjustment</b>	by plastic knob with snap-lock
<b>Relieving function</b>	relieving, optionally non-relieving
<b>Gauge port</b>	G $\frac{1}{8}$ on both sides of the body, screw plugs supplied
<b>Mounting position</b>	any
<b>Temperature range</b>	0 °C to 50 °C / 32 °F to 122 °F, for appropriately conditioned compressed air down to -30 °C / -22 °F
<b>Material</b>	Body: brass at R364, aluminium at R374 Spring cage: glass fibre reinforced plastic, optionally brass Elastomer: NBR/Buna-N, optionally FKM Inner valve: brass, optionally stainless steel

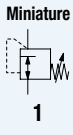
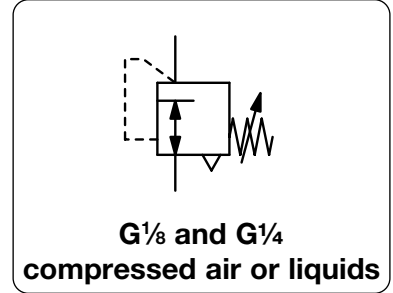

Dimensions			Flow rate		Connection thread	Pressure range	Order number
A	B	C	m <sup>3</sup> /h*1	l/min*1	G	bar	

Brass pressure regulator					supply pressure max. 21 bar, relieving	R364
35	76	12	27	450	G $\frac{1}{8}$	R364-010 R364-01A R364-01B R364-01C R364-01D
35	76	12	27	450	G $\frac{1}{4}$	R364-020 R364-02A R364-02B R364-02C R364-02D



R364  
made of brass

Aluminium pressure regulator					supply pressure max. 21 bar, relieving	R374
35	76	12	27	450	G $\frac{1}{8}$	R374-010 R374-01A R374-01B R374-01C R374-01D
35	76	12	27	450	G $\frac{1}{4}$	R374-020 R374-02A R374-02B R374-02C R374-02D



R374  
made of aluminium

## Special options, add the appropriate letter

<b>non-relieving</b>	without relieving function	R3.4-0..K
<b>adjustment lock</b>	socket wrench adjustment, height 64 mm	R3.4-0..T
<b>free of grease and oil</b>	specially cleaned, suitable for oxygen	R3.4-0..L
<b>FKM elastomer</b>	inner parts made of brass	R3.4-0..X64
	inner parts made of stainless steel	R3.4-0..X08

## Accessories, enclosed

<b>pressure gauge</b>	Ø 40 mm, 0...*2 bar, G $\frac{1}{8}$	MA4001-...*2
<b>mounting bracket</b>	made of steel	BW30-02
<b>mounting nut</b>	made of plastic	M30x1,5K
	made of aluminium	M30x1,5A



R364-02CT with adjustment lock      R364-02CX82 brass throughout

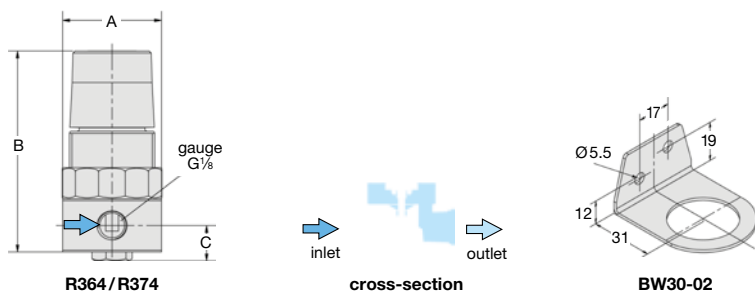

R364 / R374

cross-section

BW30-02

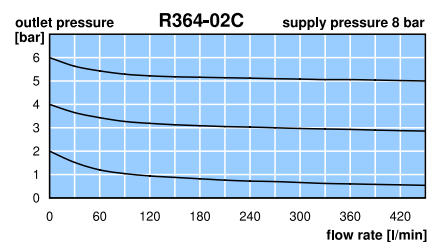

\*1 at 8 bar supply pressure, 6 bar outlet pressure and 1 bar pressure drop  
\*2 01 = 0...1 bar, 02 = 0...2,5 bar, 04 = 0...4 bar, 10 = 0...10 bar, 16 = 0...16 bar

\* Product group

Gauges: see chapter for measuring devices

PDF CAD  
www.aircom.net



Order example:  
R364-010

# MINIATURE PRECISION PRESSURE REGULATOR $\nabla$ 30 MM, WITH FLANGE

R308

<b>Description</b>	Precision pressure regulator, made of plastic, with diaphragm, with tamper-proof knob and without constant bleed. Excellent for portable systems thanks to small size and light weight of only 70 g.
<b>Media</b>	compressed air or non-corrosive gases
<b>Supply pressure</b>	max. 10 bar
<b>Adjustment</b>	by plastic knob with snap-lock
<b>Relieving function</b>	relieving, optionally non-relieving
<b>Gauge port</b>	not available
<b>Mounting position</b>	any
<b>Temperature range</b>	0° C to 60 °C / 32 °F to 140 °F
<b>Material</b>	Body: POM Elastomer: NBR/Buna-N Inner valve: brass

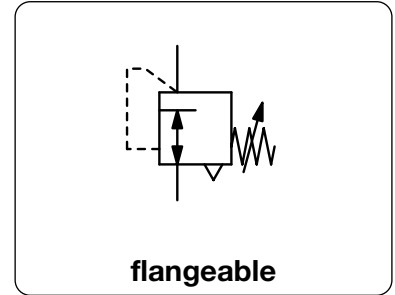

Dimensions		Flow rate	Supply pressure	Connection	Pressure range	Order number
A	B	l/min*1	max. bar	flange	bar	
mm	mm					

Precision regulator with flange	supply pressure max. 10 bar, relieving, without constant bleed	R308				
30	64	200	10	flange	0 ... 0.25	R308-P00
					0.2 ... 2.5	R308-P0B
					0.2 ... 3.5	R308-P0C
					0.2 ... 8.0	R308-P0D



R308 flangeable

## Special options, add the appropriate letter

<b>non-relieving</b>	without relieving function	R308-P0. K
<b>or oxygen</b>	specially cleaned, with oxygen grease	R308-P0. K15

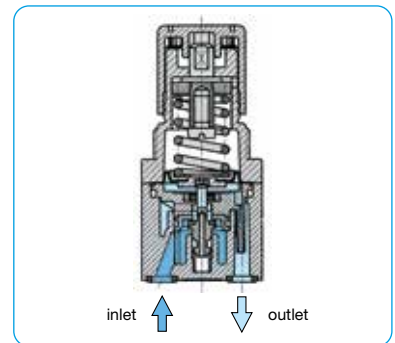

cross-section

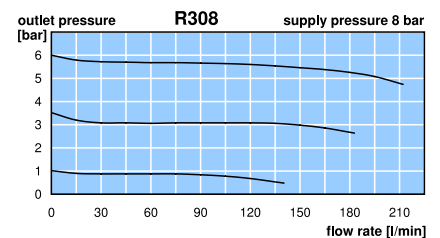
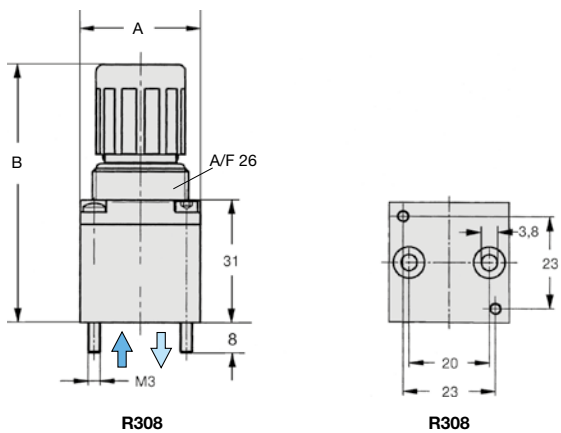

\*1 for compressed air: 8 bar supply pressure, 6 bar outlet pressure and 1 bar pressure drop

\* Product group

PDF CAD  
www.aircom.net

Order example  
R308-P00

# CARTRIDGE PRESSURE REGULATOR

RC



<b>Description</b>	Piston-operated cartridge pressure regulator suitable for assembly block.
<b>Media</b>	compressed air filtered to 50 µm, lubricated or unlubricated
<b>Supply pressure</b>	max. 10 bar
<b>Adjustment</b>	by knurled-head screw with locknut
<b>Relieving function</b>	relieving
<b>Gauge port</b>	not available
<b>Mounting position</b>	any
<b>Temperature range</b>	0 °C to 60 °C / 32 °F to 140 °F, for appropriately conditioned compressed air down to -30 °C / -22 °F
<b>Material</b>	Body: nickel-plated brass Elastomer: NBR/Buna-N

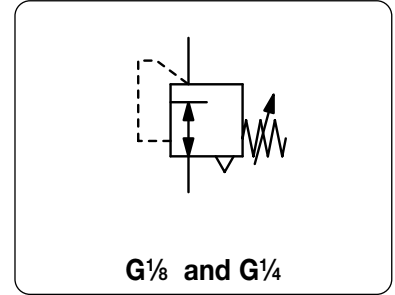

Dimensions				Flow rate	Supply pressure	Connection thread	Pressure range	Order number
A	B	C	A/F	l/min*1	max. bar	G	bar	

Cartridge regulator					supply pressure max. 10 bar, relieving, without constant bleed	RC
15	57	15	14	150	10	G <sup>1</sup> / <sub>8</sub> 1... 8 bar <b>RC-01C</b>
19	63	18	17	260	10	G <sup>1</sup> / <sub>4</sub> 1... 8 bar <b>RC-02C</b>



Step drill for cartridge seat				RCS
16	-	-	-	G <sup>1</sup> / <sub>8</sub> <b>RCS-01</b>
20	-	-	-	G <sup>1</sup> / <sub>4</sub> <b>RCS-02</b>

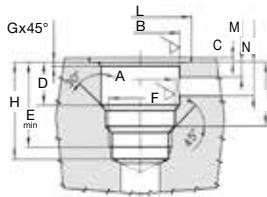

drilled hole

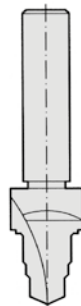

RCS

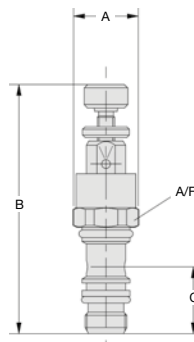

RC

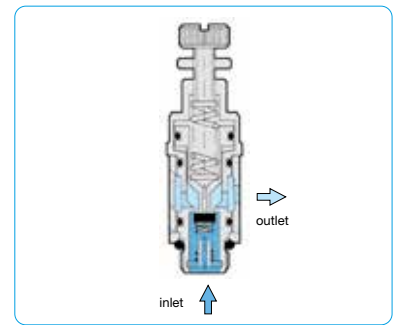

drill	F	A	B	C	D
RCS-01	1/8	9.8 - 0.1/-0	11.2 ± 0.05	0.5 ± 0.5	15.6 ± 0.07
RCS-02	1/4	13.5 + 0.1/-0	14.4 ± 0.05	0.5 ± 0.5	17.5 ± 0.07

drill	E	G	H	I	L	M	N
RCS-01	24.6	0.3	27	18.1 ± 0.2	15.4	3.5	12
RCS-02	28	0.4	31.2	20.8 ± 0.2	19.4	3.5	13.5

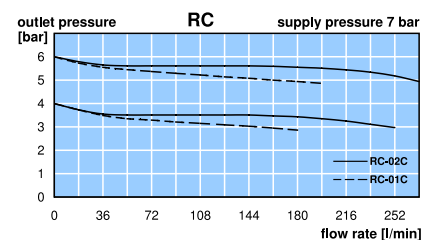

\*1 at 7 bar supply pressure, 6 bar outlet pressure and 1 bar pressure drop

\* Product group

PDF CAD  
www.aircom.net



Order example:  
**RC-01C**